

**SOLEX**

**SELECTION AND TUNING  
OF THE CARBURETOR**

*Arnolt Corporation*

WARSAW, INDIANA, U.S.A.

\$ 2.00  
PER COPY

**Some SOLEX Carburetors**



Type 28 VFIS (Downdraught Carburetor)

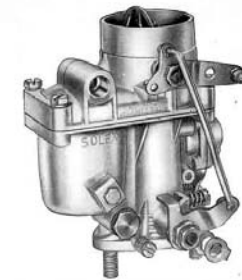

Type 28 PCI (Downdraught Carburetor)



Type 32 PICB (Downdraught Carburetor)

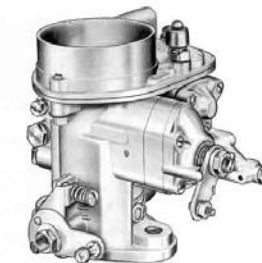

Type 40 ICB (Downdraught Carburetor)



Type 32 PAITA (Downdraught Compound Carburetor)



## SELECTION AND TUNING OF THE CARBURETOR

### CONTENTS

I. PREFACE . . . . .	5
Survey of the Variable Parts . . . . .	6
II. SELECTION OF THE CARBURETOR . . . . .	7
1. Selection of the Direction of Air Flow . . . . .	8
2. Selection of the Number of Carburetors . . . . .	8
3. Selection of the Carburetor Size . . . . .	8
III. THE FITTING OF CARBURETORS . . . . .	9
1. The Carburetor . . . . .	9
2. The Carburetor Throttle Control Linkage . . . . .	10
IV. DESCRIPTION OF THE CARBURETOR . . . . .	11
1. The Float System . . . . .	11
2. The Starter System . . . . .	11
A. The Starter Disc Valve . . . . .	11
a) Simple Starter . . . . .	12
b) Bi-starter . . . . .	12
c) Progressive Starter . . . . .	14
B. The Strangler . . . . .	15
a) Strangler Butterfly with Air Valve . . . . .	16
b) Semi-Automatic Strangler . . . . .	16
3. The Idling System . . . . .	17
A. Idling with Mixture Control . . . . .	17
B. Idling with Air Control . . . . .	18
C. Miscellaneous . . . . .	19
a) By-pass Orifices . . . . .	19
b) Mono-jet and Bi-jet Idling . . . . .	19
4. The Main jet Circuit . . . . .	20
A. Selection of the Choke Tube K . . . . .	20
B. Selection of the Main jet Gg and the Air Correction jet a . . . . .	21
C. Selection of the Emulsion Tube s . . . . .	22
D. Jet Assemblies . . . . .	22
a) Jet Assembly No. 12 . . . . .	22
b) Jet Assembly No. 8 . . . . .	23
c) Jet Assembly No. 21 . . . . .	23
d) Jet Assembly No. 22 . . . . .	24
e) New jet Assemblies . . . . .	24
5. The Accelerator Pump . . . . .	25
6. The Enrichment Device . . . . .	30

V. TUNING THE CARBURETOR . . . . .	31
1. A Carburetor for Normal 4 Cylinder Engines . . . . .	31
2. A Carburetor for 4 Cylinder Sports Engines, for 6 or 8 Cylinder Engines or for Supercharged Engines . . . . .	32
3. A Carburetor for 1, 2 or 3 Cylinders . . . . .	33
VI. ALTITUDE CORRECTOR . . . . .	34
VII. DEPRESSION OPERATED IGNITION ADVANCE . . . . .	35
VIII. OPERATING FAULTS . . . . .	35
1. Leakages . . . . .	35
2. Cold Starting Difficult or Impossible . . . . .	35
3. Hot Starting Difficult or Impossible . . . . .	36
4. Bad Idling . . . . .	36
5. Poor Acceleration . . . . .	36
6. Insufficient Top Speed . . . . .	37
7. Insufficient Power when Climbing . . . . .	37
8. Overheating . . . . .	37
9. Pinking . . . . .	37
10. Mixture too Rich . . . . .	37
11. Mixture too Weak . . . . .	38
12. Backfiring in the Carburetor . . . . .	38
13. Detonation in the Exhaust . . . . .	38
14. Heavy Consumption . . . . .	38

#### APPENDIX

AUTOMATIC STARTER (HOT AIR) . . . . .	40
1. Model BICT . . . . .	40
2. Model ICBT . . . . .	41
3. Model IBT . . . . .	42
4. Setting and Dismounting . . . . .	44
5. Re-fitting of an Autostarter . . . . .	46

## I. PREFACE

This booklet is written for the manufacturers of four stroke engines and for those who already have some experience of carburetor tuning. Some knowledge of general carburetor technique is assumed.

For the better understanding of this booklet the following points should be noted.

- a) The contents of this booklet apply to four stroke engines only. As a rule for two stroke engines of equal capacity a carburetor of a larger size is necessary. Our experience and advice in regard to these is at your disposal at any time.
- b) The following advice is mostly based on practical experience as in preparing this pamphlet consideration has been given to the fact that few garages or repair shops have installed test benches.
- c) It seems desirable to explain some of the terms which are frequently repeated:

**Capacity** – the volume (cm<sup>3</sup>) of a cylinder calculated from the bore and stroke.

**Total capacity** – the total volume of all cylinders of an engine (cm<sup>3</sup> or litres).

**Maximum power revolutions** – the number of revolutions per minute at which the engine gives its maximum power output (n by N<sub>max</sub>).

**Peak revolutions** – the number of revolutions per minute which the engine can reach at full throttle (n<sub>max</sub>).

"Maximum power revolutions" and "Peak revolutions" are not identical as after reaching its maximum, the power output drops slightly whilst the number of revolutions will increase slightly (fig. 1).

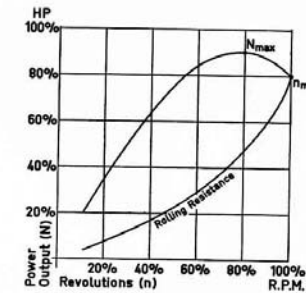

Fig. 1 Maximum Power Revolutions and Peak Revolutions

**Full load** – the working condition of the engine with a fully opened throttle butterfly irrespective of the number of revolutions which can vary considerably (i.e. accelerating, climbing).

**Part load** – the working condition of the engine in normal use when the throttle butterfly is not fully opened.

The so called "Part load point" is important in adjusting the carburetor. This expression is generally understood as the working condition of the engine at about three quarters of peak revolutions which is approximately half the maximum power, with a moving vehicle, driven on a level road this represents a steady speed of about three quarters of the speed maximum.

- d) Where full consumption graphs are illustrated the horizontal axis indicates the number of revolutions in percentages of the peak revolutions and the vertical axis shows the fuel consumption in litres per 100 kilometers. It is understood that the vehicle is driven on a level, straight road.

e) All SOLEX carburetor parts (Choke tubes, Jets, Emulsion tubes etc) are marked with their size or other identification (i. e. numbered). Where possible genuine parts are marked "SOLEX" to eliminate "pirate" or spurious parts.

#### SURVEY OF THE VARIABLE PARTS

Variable Part	Abbreviations	Remarks
Choke Tubes	K	Made in sizes increasing in m/m in some cases by 1/2 m/m a) Example of marking: 32-23 to read - diameter of emulsion chamber = 32 m/m - diameter of choke tube = 23 m/m The choke tube fits a carburetor with a 32 m/m bore. b) Example of marking: 35 x 40-28 to read - diameter of emulsion chamber = 40 m/m - diameter of choke tube = 28 m/m The choke tube fits a carburetor with a bore of either 35 or 40 m/m.
Main Jets	Gg G	Made in sizes increasing by 5/100 and in some cases by 2.5/100 An "0" is placed in front of the size marking of this type of main jet Gg. Examples: 090 - 095 - 0100 - 0102.5 - 0105 - 0107.5 - 0110 Made in sizes increasing by 5/100 and in some cases by 2.5/100 The size marking of the main jet G (for the older BF types) is combined with the marking of the emulsion tube which is an integral part of the jet. Examples: 105 x F - 110 x 51 - 112.5 x 58 - 115 x 56
Air Correction Jets	a	Made in sizes increasing by 10/100 and in some cases by 5/100 Examples: 195 - 200 - 210 - 220 - 230
Pilot Jets	g g	Made in sizes increasing by 5/100 and in some cases by 2.5/100 Examples: g 45 - g 47.5 - g 50 - g 52.5 - g 55. For carburetors of the older BF types: Made in sizes increasing by 5/100. To distinguish pilot jets of this type the size is prefaced by the letter "0" Examples: 040 - 045 - 050 - 055
Pilot Jets air bleeds	u	Made in sizes increasing by 1/10 Examples: 1.2 - 1.3 - 1.4 - 1.5
Pump Jets	Gp	Made in sizes increasing by 5/100 Examples: 40 - 45 - 50 - 55
Economy Jets	Gu	Made in sizes increasing by 10/100 Examples: 50 - 60 - 70 - 80
Starter Fuel Jets	Gs	Made in sizes increasing by 10/100 and in some cases by 5/100 Examples: 80 - 90 - 95 - 100 - 105 - 110
Starter Air Jets	Go	Made in sizes increasing by 5/10 Examples: 3 - 3.5 - 4 - 4.5 - 5
Emulsion Tubes	s	Made with a variety of different drillings. To distinguish each type they are marked with a number. Nos. 0-9 and over 40 = emulsion tubes with 4 m/m outside diameter. Nos. 10-37 = emulsion tubes with 3.5 m/m outside diameter.

Variable Part	Abbreviations	Remarks
Injector tubes	i	For the various types of carburetor these are available in two versions: a) "High" injector with the outlet of the tube level with the air correction jet and outside the area of greatest depression. b) "Low" injector with the outlet of the tube above the spraying orifices of the main well and in the venturi throat. Various injector tubes are available with their calibration marked accordingly.
Needle Valve	P	Available in sizes 1.2 - 1.5 - 2 - 2.5 - 3. The size marked indicates the size of the orifice in the needle valve through which the fuel flows.

The sizes indicated on Gg, G, a, g, Gp, Gu and Gs jets correspond approximately to their diameter in 1/100 m/m, but these parts are not calibrated by their diameter, but by their flow capacity. These jets cannot be checked by calibre needles. Enlarging or hammering on jets makes them useless. It is always advisable to obtain genuine spare parts which ensures that they are correctly calibrated.

## II. SELECTION OF THE CARBURETOR

SOLEX carburetors are distinguished by:

- the type
- the bore of the throttle chamber
- the model.

There are three types, distinguished by the direction of flow through the carburetor, and made to correspond with the arrangement of the engine induction manifold (fig. 2):

- Upraight carburetors
- Horizontal carburetors and
- Downraught carburetors.

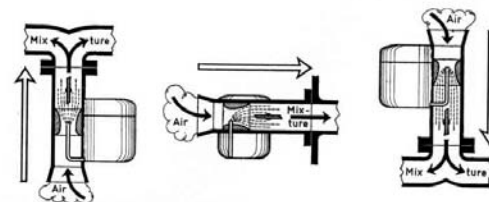

Fig. 2 Types of carburetor  
 a) Upraight carburetor    b) Horizontal carburetor    c) Downraught carburetor

According to the layout of the induction system the following can now be foreseen (fig. 3):

- Simple carburetor for a single induction manifold
- Dual port carburetor for two induction manifold
- Dual port compound carburetor for a single induction manifold.

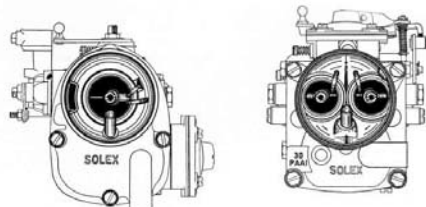

Fig. 3 Types of carburetors

a) Simple carburetor

b) Dual port carburetor

### 1. Selection of the Direction of Air Flow

It is first necessary to determine which type of carburetor is best suited to the engine.

If an old carburetor has to be replaced it is usually easy to see from the flange which type of carburetor is required.

With modern vehicles a downdraught carburetor is generally used, for the simple reason that it is readily accessible from all sides. On sports cars and racing cars the bonnet design usually means that a horizontal carburetor has to be used. Updraught carburetors are used for engines where the fuel is gravity fed.

### 2. Selection of the Number of Carburetors

It is necessary to determine the number of carburetors to be used bearing in mind the question of using simple or dual port carburetors. Usually the make or type of engine determines whether one or more carburetors must be used. The use of more than one carburetor is generally required with sports or racing cars. The purpose of using multiple carburetors is to reduce the length of the induction manifold and most important of all to reduce the number of bends which obstruct the free passage of the air/fuel mixture.

It is the duty of the carburetor expert to select the correct type of carburetor and the number of carburetors to be used. He has the possibility of getting the best possible output from the engine when he selects dual or several carburetors.

### 3. Selection of the Carburetor Size

To determine the diameter of carburetor the following engine details must be known:

- the capacity of a cylinder
- the number of cylinders to be fed by one carburetor
- the peak revolutions of the engine.

The following formula will indicate approximately the correct size of SOLEX carburetor. The following symbols are used:

- $d$  – the required diameter of the carburetor in m/m
- $V_h$  – the capacity of a cylinder in  $\text{cm}^3$
- $n$  – the peak revolutions in 1000 revolutions per minute.

If one carburetor feeds 1, 2, 3 or 4 cylinders

$$d = 0.82 \cdot \sqrt{V_h \cdot n}$$

If one carburetor feeds 6 cylinders

$$d = \sqrt{V_h \cdot n}$$

If one carburetor feeds 8 cylinders

$$d = 1.15 \cdot \sqrt{V_h \cdot n}$$

Example: Taking a four cylinder engine with a total capacity of 1200  $\text{cm}^3$  and with peak revolutions of 4500 r.p.m. (revolutions per minute)

$$\text{Equation: } d = 0.82 \cdot \sqrt{300 \cdot 4.5}$$

Therefore:  $d = 30$

Result: The engine requires a carburetor with a diameter of 30 or 32 m/m.

If the engine is fitted with a supercharger all cylinders are fed together through the supercharger. In this case the following symbols are used:

$p$  – the absolute pressure at the outlet of the supercharger denoted in m/m of mercury

$Z$  – the number of cylinders fed by the supercharger (equal to or larger than 4).

The formula for determining the diameter of the SOLEX carburetor is then as follows:

$$d = 0.41 \cdot \sqrt{V_h \cdot n \cdot Z \cdot \frac{p}{760}}$$

Example: Taking a four cylinder supercharged engine with a total capacity of 1200  $\text{cm}^3$  with peak revolutions of 6000 r.p.m. and the boost pressure at the outlet of the supercharger 400 m/m of mercury.

The equation is as follows:

$$d = 0.41 \cdot \sqrt{300 \cdot 6 \cdot 4 \cdot \frac{760 + 400}{760}}$$

$$d = 0.41 \cdot \sqrt{7200 \cdot \frac{1160}{760}}$$

Therefore:  $d = 43$

Result: The supercharged engine requires a carburetor with a diameter of 43 m/m (if not available the next size larger will be needed).

## III. THE FITTING OF CARBURETORS

Special attention must be given to the fitting of the carburetor.

### 1. The Carburetor

The carburetor should be fitted with the float chamber forward to avoid fuel starvation when accelerating or climbing (Fig. 4).

Flange gaskets should not be thicker than 1 m/m as thicker or soft gaskets may cause the flange to warp.

The carburetor securing nuts should be tightened evenly to prevent distortion or breakage of the flange. Where possible shakeproof washers should be used.

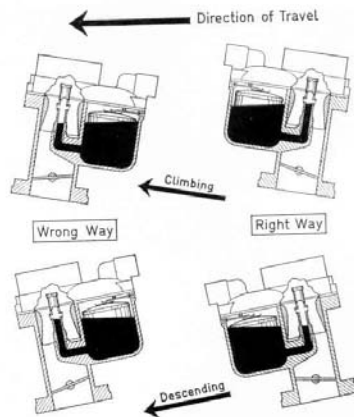

Fig. 4  
Position of the Float Chamber

## 2. The Carburetor Throttle Control Linkage

When fitting the throttle control linkage it is essential to ensure that there is no play in the controls and no tension on the levers.

Make sure that the throttle butterfly opens and closes completely.

Keep the control operation in mind when fitting the controls if the throttle lever is connected to the control rod with a ball joint.

When fitting the controls avoid blunt angles which can cause the controls to stick or slip out of position.

When fitting multiple carburetors it is suggested that the controls are arranged as shown in fig. 5 as with this method tuning is simplified and the controls are unlikely to stick.

It is not advisable to connect the throttle spindles in a direct line, i.e. end to end, and to operate them from one end, as with this method it is practically impossible to get the throttle butterflies to open and close simultaneously. The length of the operating spindle is such that it is liable to twist.

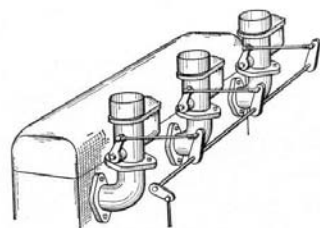

Fig. 5  
Control layout for multiple carburetors

## IV. DESCRIPTION OF THE CARBURETOR

All SOLEX carburetors consist of several circuits each of which has a specific function and its own adjustable parts. These circuits are:

1. The Float System
2. The Starter System
3. The Idling System
4. The Main Jet Circuit
5. The Accelerator Pump and
6. The Enrichment Device.

### 1. The Float System

The Float System regulates the fuel level in the carburetor (fig. 6).

The fuel must be maintained at a constant level, it is fixed for all carburetors for a fuel pump pressure equal to 1-2 metres of water and for fuel with a specific gravity of 0.730.

For higher fuel pump pressures a smaller needle valve must be used.

Variations in the specific gravity of the fuel and the pump pressure can be compensated for by the use of washers of different thickness under the needle valve.

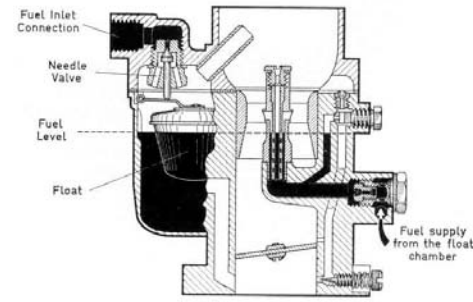

Fig. 6 The Float System

### 2. The Starter System

There are two principle arrangements of the starter system: the Starter Disc Valve and the Strangler.

#### A. The Starter Disc Valve

The starting circuit with disc valve (fig. 7) ensures instant starting with a cold engine, idling when cold and a smooth transfer.

It has two adjustable parts, the starter fuel jet Gs and the starter air jet Ga.

The starting device should be used only when the engine is cold and has not reached its normal working temperature.

As soon as the engine is warm the starting device should be put out of action, to prevent the excessive use of fuel. The starting device should not be used when attempting to start a hot or warm engine.

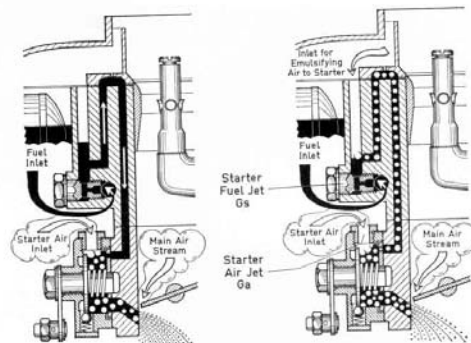

Fig. 7 Operation of the Starter Disc Valve

a) Phase 1

b) Phase 2

When operating the starting device the throttle butterfly must be kept closed in the idling position.

The starting device may be operated automatically or manually. Only the second method will be described in the following text.

Dependant upon the carburetor type there are several versions of the starter disc valve.

#### a) Simple Starter

Operation of the starter control causes the rotation of the disc valve which has only one drilling for a rich starting mixture (fig. 8).

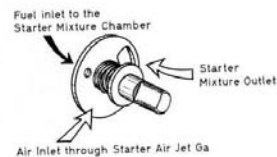

Fig. 8

Disc Valve of a simple Starter

In this version the starter control must be pulled out completely (Starter in operation) or returned fully home (Starter out of action). The starter control must never be used in an intermediate position.

#### b) Bi-Starter

The disc valve of the bi-starter has two different drillings, one for a "rich" starting mixture the other for a "weaker" starting mixture (fig. 9).

This type has three positions:

- Starter control fully pulled out = Cold starting
- Starter control halfway out = Warm starting
- Starter control pushed home = Starter out of action.

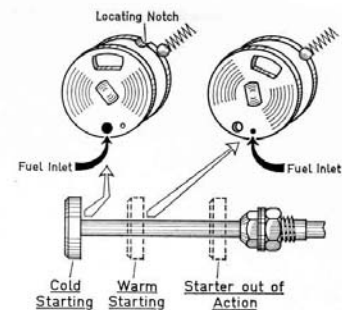

Fig. 9 Disc Valve and Starter Control of a Bi-Starter

In the cold starting position the mixture is very rich to ensure instant starting of the cold engine. In the warm starting position, located by a notch on the disc valve and thus indicated on the movement of the starter control, the starting mixture is substantially weakened due to the small transfer drilling. This position should be used as soon as the engine warms up after a short time in the cold starting position or when a warm engine has to be restarted.

Dependant on the size of the carburetor, the bi-starter is made in three sizes (small, medium and large). The larger size differs from the other types by the addition of a permanent air vent of 3 mm in diameter, so that a small starter air jet Ga can be used. The line inserted on fig. 10 shows approximately the correct size of the starter fuel jet Gs and the starter air jet Ga in relation to the total capacity of the engine. In exceptional circumstances it will be found by experiment, that the size of the starter fuel jet Gs varies from the size indicated theoretically.

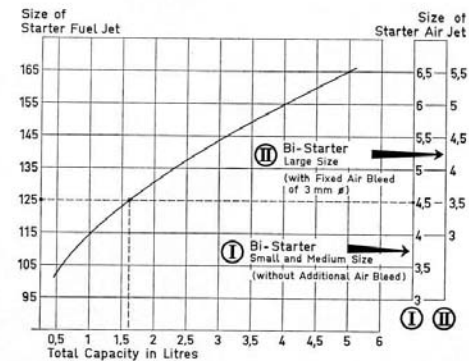

Fig. 10 Approximate sizes of jets for bi-starter in relation to total capacity

### c) Progressive Starter

The progressive starter differs from those previously described as there are no definite starter valve positions and the weakening of the starter mixture is spread over the whole movement of the starter. When the starter control is pulled out fully the richest mixture is delivered. As the starter control is pushed home the mixture is progressively weakened until, when the control is fully home, the starter is completely out of action.

Air intake through a calibrated hole in the starter valve



Fig. 11

Starter Valve of a progressive starter

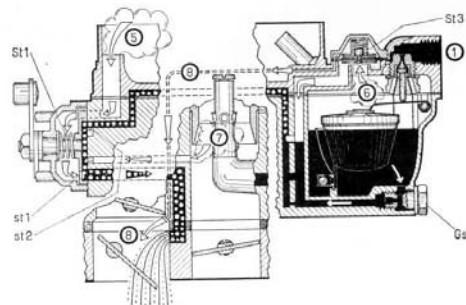
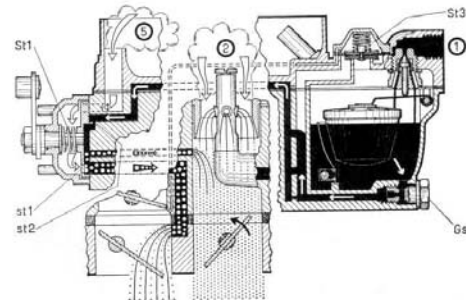

Fig. 12

Operation of a progressive Starter

a) Cold Starting position



b) Intermediate position

Gs Starter Fuel Jet  
St1 Starter disc Valve  
St3 Starter air valve  
st1 Calibrated hole in starter valve  
st2 Starter progression orifice

1 Fuel inlet  
2 Main air stream  
5 Starter air inlet  
6 Additional air intake to starter valve  
7 Additional air intake to starter mixing chamber  
8 Depression acts

In the progressive starter the formation of the starting mixture commences in the starter valve which has various shaped cavities on the inner face. In these cavities, fuel metered by the starter fuel jet Gs, or rather a preformed emulsion of fuel and air drawn from the additional air intake to the starter valve mix with air entering through a calibrated hole in the starter valve (fig. 12 a). In this type the calibrated hole in the starter valve replaces the starter jet Gs. Rotation of the starter valve gradually reduces the size of the orifice through which the fuel passes resulting in a progressive weakening of the starter mixture similar to the warm running position of the bi-starter.

The progressive starter has an air valve which opens and closes the intake for the additional air supply.

It also has a channel between the cavity in the starter valve and the mixing chamber of the carburetor. Through this channel, known as the "quick drive away channel" additional fuel is delivered when the vehicle is driven away and the throttle butterfly opened with the starter still in operation (fig. 12 b). Thus a greater flexibility is given when driving away with a cold engine.

### B. The Strangler

The strangler is the simplest form of starting device. It consists of a butterfly, simple in operation, which closes the air intake to the carburetor.

In contrast to the starter disc valve, when the strangler is operated the throttle butterfly must be slightly opened. This is ensured by mechanical linkage between the strangler lever and the throttle lever (fig. 13).

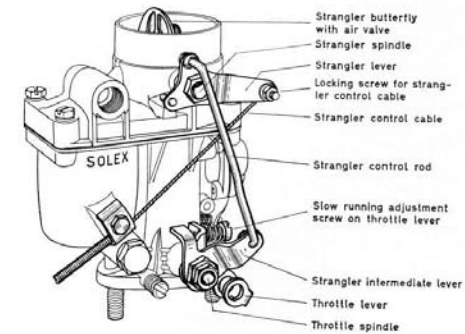

Fig. 13 Linkage between the strangler lever and the throttle lever

When starting the engine depression, acting on the main jet system through the open throttle butterfly, causes the discharge of fuel.

The start takes place in the same effective manner as with the starter disc valve, but the adjustment of the mixture strength in the warming-up period depends on the experience of the driver in operating the starter control.

There are two types of strangler: the strangler with air valve and the semiautomatic strangler.



a) Strangler Butterfly with Air Valve (Fig. 14)

In this type the offset strangler butterfly has a spring loaded air valve on the larger side, which opens as soon as the engine starts and it is subjected to depression. This allows the air for the starting mixture to enter the mixture chamber.

The strangler butterfly remains in the closed position.

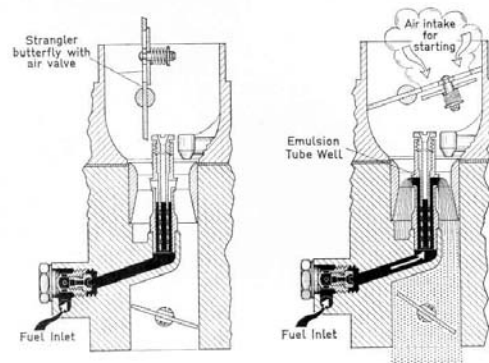

Fig. 14 Strangler Butterfly with Air Valve

a) Normal position

b) Starting position

b) Semi-Automatic Strangler (Fig. 15)

In this type the air for the starting mixture passes the strangler butterfly. The strangler butterfly, which is offset on a freely moving spindle, flutters rapidly its movement being determined by depression on one side and by the strangler butterfly spring on the other.

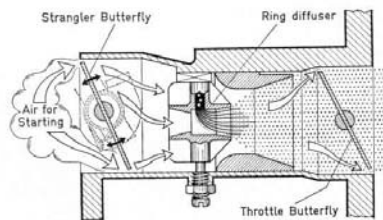

Fig. 15 Semi-Automatic Strangler

### 3. The Idling System

#### A. Idling with Mixture Control (Fig. 16)

The idling system consists of four adjustable parts:

- the pilot jet g,
- the pilot jet air bleed u,
- the volume control screw W which controls the output of the pilot jet and
- the slow running adjustment screw Z controlling the idling speed.

Great attention must be given to the correct adjustment of the idling. Even with the best carburetors incorrect adjustment of the idling can cause trouble in operation. We therefore advise that great care should be taken in making the idling adjustment.

Check the condition of the plugs and make sure that plug gaps (0.6-0.8 mm - follow the manufacturers specification) are correct before adjusting the idling.

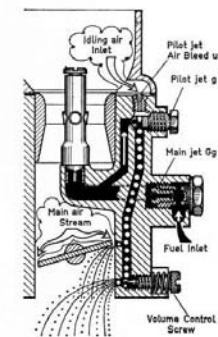

Fig. 16 Idling with mixture control

When adjusting the idling of simple carburetors proceed as follows:

1. Let the engine reach its normal working temperature.
2. Screw in the slow running adjustment screw Z to increase idling speed slightly.
3. Unscrew the volume control screw W until the engine commences to run unevenly (to "hunt") then screw in slowly until the engine runs evenly.
4. Slowly unscrew the slow running adjustment screw Z until the idling speed returns to normal.
5. If the engine is then "hunting" slightly, screw in the volume control screw W a little more.

When adjusting the idling of dual port carburetors proceed as follows:

1. Let the engine reach its normal working temperature then switch off.
2. Screw both volume control screws W in fully then unscrew each one complete turn.
3. Start engine.
4. Adjust slow running adjustment screw Z to give correct idling speed.
5. If the engine commences to "hunt" (mixture too rich), screw both volume controls W in slightly, and by an equal amount.
6. If the engine commences to "stagger" (mixture too lean), unscrew both volume control screws W by an equal amount.

**Note:**

Unscrewing the volume control screw W makes the idling mixture richer, screwing it in makes the mixture weaker. The volume control screw W should never be screwed in too tightly.

The "normal" idling speed is generally considered to be approximately 500 r.p.m. We recommend that, with modern engines, the idling speed should never be set at slower speeds; on the contrary with some engines the speed may be increased. If the slow running is set too slow it is frequently the cause of stalling.

A revolution counter simplifies the adjustment and enables the idling to be adjusted very accurately and we strongly recommend its use.

### B. Idling with Air Control (Fig. 17)

Some of the updraught and horizontal carburetors of the older BF type have idling with air control. This idling system incorporates three adjustable parts:

- the pilot jet g
- the air regulating screw W and
- the slow running adjustment screw Z.

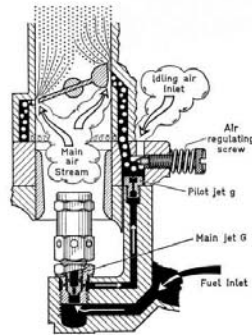

Fig. 17 Idling with air control

When adjusting the idling of these carburetors proceed as follows:

1. Let the engine reach its normal working temperature.
2. Screw in the slow running adjustment screw Z to increase idling speed slightly.
3. Screw in the air regulating screw W until the engine commences to run unevenly (to "hunt") then unscrew slowly until the engine runs evenly.
4. Unscrew the slow running adjustment screw Z slowly until the idling speed returns to normal (in this case 400-500 r.p.m.).

**Note:**

Unscrewing the air regulating screw W weakens the idling mixture, screwing it in makes it richer. The air regulating screw should never be screwed in too tightly.

### C. Miscellaneous

#### a) By-pass Orifices

The drillings in the throttle chamber close to the throttle butterfly, are known as the "by-passes". There may be one or more of these orifices which are connected with the idling system.

The purpose of the "by-pass" is to ensure a smooth transfer from the idling to the normal driving position, i.e. to the main jet circuit.

The position of "by-pass" drilling or drillings may be varied. Not every new carburetor is therefore suitable for a given engine - the position of the "by-pass" needs careful checking to see which gives the best transfer.

If, after fitting a new carburetor the transfer proves unsatisfactory due to a "flat-spot" when accelerating slowly, the throttle butterfly should, if possible be located on the "flat-spot". This can be done by adjustment of the slow running screw. The carburetor should then be removed and the position of the "by-pass" in relation to the edge of the throttle butterfly determined.

A "flat-spot" usually occurs when accelerating if either:

- a) the throttle butterfly has passed the "by-pass" orifice and the main jet has not yet started to operate (fig. 18a) or
- b) if to the contrary, the throttle butterfly has not yet reached the "by-pass" orifice (fig. 18b).

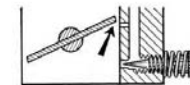

a) The throttle butterfly has passed the "by-pass" orifice.

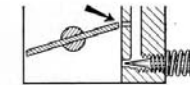

b) The throttle butterfly has not reached the "by-pass" orifice.

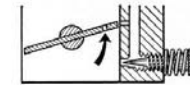

c) A hole in the throttle butterfly causes the "by-pass" orifice to discharge slower.

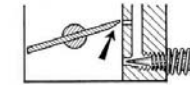

d) A bevelled edge on the throttle butterfly causes the "by-pass" orifice to discharge earlier.

Fig. 18 Throttle butterfly and by-pass orifices

In the following we shall endeavour to explain how the "by-pass" and the throttle butterfly edge may be brought closer together or further separated.

If the "by-pass" orifice is desired to operate only with a wider opening of the throttle butterfly a hole drilled in the edge of the throttle butterfly should prove satisfactory. This enables the throttle butterfly to be closed slightly more when idling (fig. 18c). This arrangement is a satisfactory remedy in case a).

If the "by-pass" orifice is intended to operate with a smaller throttle butterfly opening a small amount should be filed off the lower edge of the throttle butterfly on the side nearest the "by-pass". This brings the edge of the throttle butterfly nearer to the "by-pass" (fig. 18d). In this manner it is possible to help in case b).

#### b) Mono-jet and Bi-jet Idling

In the majority of carburetor types, fuel for idling is taken after passing through the main jet and, so to speak, controlled by the main jet (see fig. 23).

This arrangement results in a small amount of air entering through the slow running system as the engine speed increases under normal working conditions affecting the formation of the mixture. This arrangement is known as a "mono-jet" system as the formation of the mixture is effected entirely through the main jet, it is also described as an dependent idling system.

With an independant idling system the fuel for idling is taken before it passes through the main jet (see fig. 24). In this case the idling system is completely independent and under normal operation always affects the formation of the mixture, therefore very careful adjustment of idling setting is required. This is known as the "bi-jet" system.

On the same engine the main jet will always be smaller with a "bi-jet" system than with a "mono-jet" system.

#### 4. The Main jet Circuit

On all modern carburetors there are four adjustable parts for normal operation as follows (fig. 19):

- the choke tube K
- the main jet Gg
- the air correction jet a and
- the emulsion tube s.

On carburetors of the older BF type there are only two adjustable parts for normal operation which are (fig. 20):

- the choke tube K
- the main jet G.

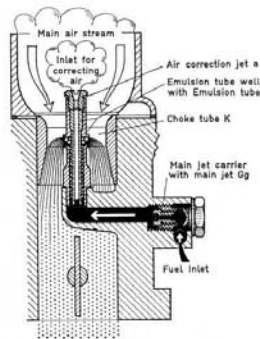

Fig. 19 Main jet circuit of a downdraught carburetor

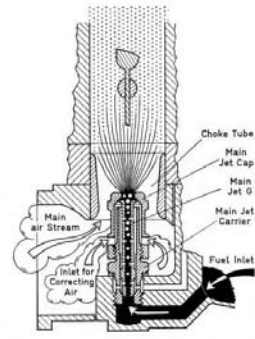

Fig. 20 Main jet circuit of a updraught carburetor

#### A. Selection of the Choke Tube K

After the size of the carburetor has been determined, the correct choke tube K has to be selected.

When a test bench is available, the choke tube to select is that which gives a power output 3-4% lower than that obtainable with larger choke tubes. This ensures a good performance from most normal engines.

To obtain the best performance over the whole revolution range it is necessary to select the choke tube which only just gives the highest output. When experimenting on the test bench main jets, large enough to ensure that there is no loss of power through weakness, should be used. Heavy fuel consumption should also be avoided although the effect of too rich a mixture is relatively unimportant.

If no test bench is available, the diameter of the choke tube can be calculated as follows, to arrive at a starting point:

After determination of the size of carburetor, as described in II. 3. multiply the result by 0.8.

In the example mentioned before, a four cylinder engine with a capacity of 1200 cm<sup>3</sup> with peak revolutions of 4500 r.p.m. the diameter of the carburetor was calculated as 30 m/m. The size of the choke tube, to serve as a starting point for tuning, should have a

$$\text{diameter } 30 \times 0.8 = 24 \text{ m/m.}$$

Usually this will be about the best size for the choke tube. Starting with this size, it is necessary to find by road test the smallest choke tube size which gives the maximum speed.

The choke tubes are different for various sizes and types of carburetor. The part numbers quoted in spare parts lists should be used.

#### B. Selection of the Main jet Gg and the Air correction jet a

The following rule of thumb can be used to decide the main jet size:

1. The size of the main jet Gg is approximately five times the size of the choke tube.

$$\begin{aligned} \text{Example: Choke tube K} &= 24 \text{ m/m} \\ \text{Main jet Gg} &= 24 \times 5 = 120 \end{aligned}$$

2. The size of the air correction jet a is approximately equal to the size of the main jet Gg + 60.

$$\begin{aligned} \text{Example: Main jet Gg} &= 120 \\ \text{Air correction jet a} &= 120 + 60 = 180 \end{aligned}$$

The affect of the main jet Gg and the air correction jet a are shown on fig. 21 and 22.

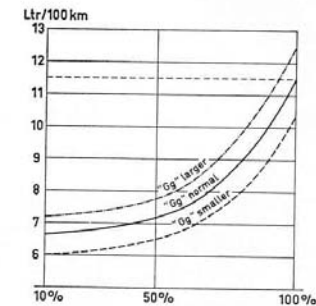

Fig. 21 Diagram of the effect of the main jet Gg

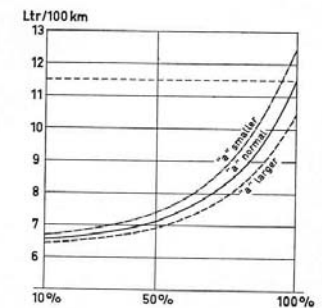

Fig. 22 Diagram of the effect of the air correction jet a

The curves on fig. 21 show the affect of the main jet Gg. It will be seen that a change of main jet affects the fuel consumption throughout the range, but the consumption curve is shifted approximately parallel to it self. Increasing or decreasing the size of the main jet affects the fuel consumption by approximately the same amount at both high and low engine speeds.

The curves on fig. 22 show the affect of the air correction jet a. They show that, as opposed to the main jet Gg a change of the air correction jet a, has a greater affect at high engine speeds than at low speeds. Increasing or decreasing the air correction jet a results in the curves getting further apart as the engine speed increases. The smaller the air correction jet is, the greater the affect of the depression upon it and consequently the enrichening of the mixture. As already stated this affect increases with the engine speed.

### C. Selection of the Emulsion Tube s

Although the emulsion tube is an adjustable part its affect is small and it is difficult to give general directions for the selection of the correct emulsion tube.

It is best to use the emulsion tube indicated in the settings list or spare parts list for the particular carburetor. In emergency a standard emulsion tube can also be used (i. e. No. "0" or No. "10").

It is advisable never to change the emulsion tube of a carburetor until after trying to eliminate minor faults which are often difficult to locate (i. e. minor flat-spots when accelerating).

Sometimes when accelerating a so called "rich flat-spot", resembling a "gulp" occurs, caused by too much fuel. This can be due either to the accelerator pump or the main jet circuit.

With pump type carburetors the setting of the pump should be changed (refer to section IV. 5.).

If the carburetor has no pump, an emulsion tube with large holes and the bottom sealed by a plug, can be tried.

On carburetors which feed only one or two cylinders, as is usual on racing cars, short emulsion tubes should be used.

### D. Jet Assemblies

The layout of the adjustable parts of the various carburetor types are known as the jet assembly. Although the working principles are the same for all carburetors, the adjustable parts are differently arranged owing to the type of carburetor and its development. The differences are mainly in the way in which the correctional air supplied and in the arrangement of the main jet.

#### a) Jet Assembly No. 12 (fig. 23)

This assembly is used on the updraught and horizontal carburetors of the older BF types. It consists of the jet carrier, the main jet G and the jet cap A.

The main jet G and the emulsion tube s are combined in one part which is marked with two numbers (i. e. 110 x 51). The first number indicates the size of the calibrated drilling (below), whilst the second indicates the position and size of the emulsion holes drilled in the side of the jet.

The emulsion holes control the automatic weakening of the mixture by the correctional air which is calibrated by the drillings in the side of the main jet cap A.

The sequence of the combined main jet and emulsion tubes is as follows:

51 - 56 - 52 - 58 - 53 - 54

For example if a size 120 main jet is used with all the foregoing emulsion tubes the addition of correctional air or the weakening increases in the order given above.

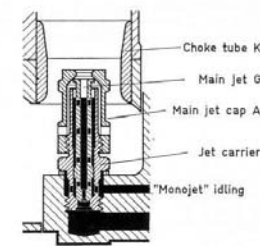

Fig. 23 Assembly No. 12

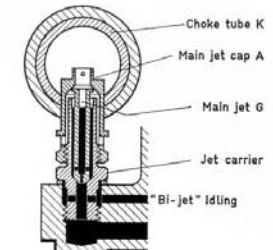

Fig. 24 Assembly No. 8

#### b) Jet Assembly No. 8 (fig. 24)

This assembly is found on many carburetors of the older BF types and is used mostly on two stroke engines.

In construction it is similar to assembly 12, it differs however, in that it has a "bi-jet" or independent idling system. As explained in section IV.3.C.b, this means that the fuel for idling is taken before it passes through the main jet whilst in assembly 12 it is taken after passing through the main jet.

The main jet G for this assembly is indicated with the letter "F" coupled with the size (i. e. 105 x F), and characterises the emulsion tube which has only two emulsion holes.

#### c) Jet Assembly No. 21 (fig. 25)

This assembly is found on the majority of modern downdraught carburetors.

It consists of an emulsion tube well with emulsion tube s, air correction jet a and the main jet carrier Y with the main jet Gg.

In this type, the emulsion tube is located in the emulsion tube well and in a simple way is held in place by the screwed in air correction jet. Dismantling and cleaning are therefore simplified.

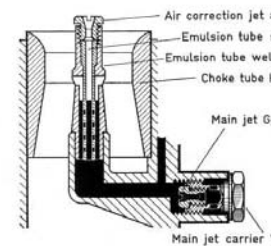

Fig. 25 Assembly No. 21

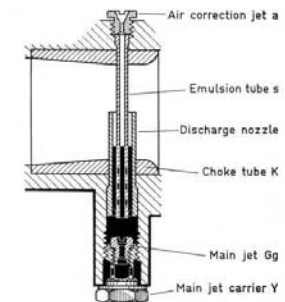

Fig. 26 Assembly No. 22

**d) Jet Assembly No. 22 (fig. 26)**

This assembly is used on modern carburetors of the horizontal type.

It consists of a discharge nozzle, the emulsion tube *s*, the air correction jet *a* and the main jet carrier *Y* with the main jet *Gg*.

It differs from assembly 21 essentially in that the air correction jet is no longer located in the middle of the main air intake, but above it, and that the emulsion tube crosses the choke tube diagonally. This facilitates dismantling and cleaning.

**e) New jet Assemblies (figs. 27 and 28)**

In horizontal and downdraught carburetors of the latest models the emulsion tube and air correction jet are no longer located centrally in the choke tube, but at the side in a cylindrical well situated in the float

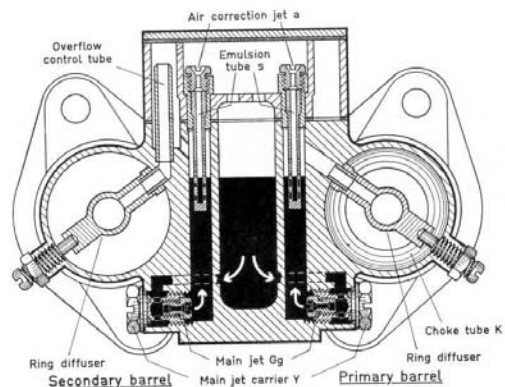

Fig. 27 Jet assembly of the 44 PHH carburetor

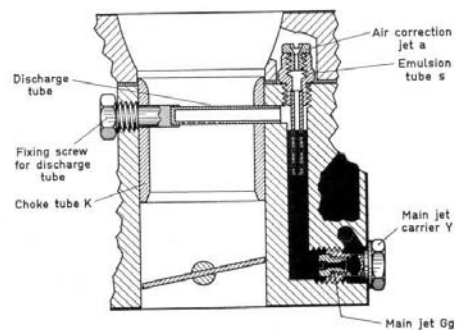

Fig. 28 Jet assembly of the 40 PII carburetor

chamber of the carburetor which is supplied with fuel through the main jet (i. e. types 44 PHH and 40 PII). This application can also be found in the secondary barrel of compound downdraught carburetors (type 32 PAITA).

The fuel mixture is discharged through a connection between the emulsion tube well and the choke tube. This connection may be a simple tube (mixture discharge tube) or it may be a ring diffuser.

**5. The Accelerator Pump**

Generally accelerator pumps are needed for acceleration, and give the greatest advantage the longer the induction manifolds are, the greater the diameter of the induction manifold or respectively the choke tube in relation to the capacity of one cylinder.

Accelerator Pumps are generally mechanically operated (fig. 29). On older types of carburetor pneumatic pumps are also found (fig. 30). In the first case the pump is connected to the throttle spindle by a control rod; in the second case it is operated by depression.

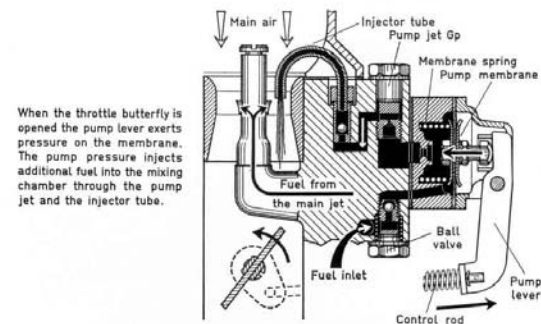

When the throttle butterfly is opened the pump lever exerts pressure on the membrane. The pump pressure injects additional fuel into the mixing chamber through the pump jet and the injector tube.

Fig. 29 Mechanically operated accelerator pump

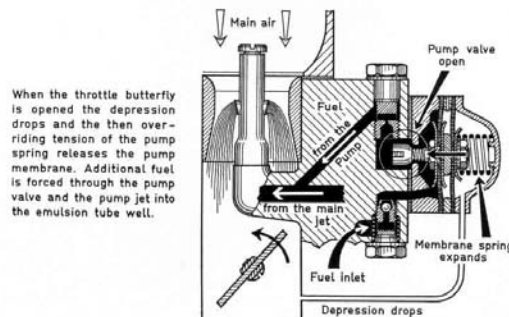

When the throttle butterfly is opened the depression drops and the then overriding tension of the pump spring releases the pump membrane. Additional fuel is forced through the pump valve and the pump jet into the emulsion tube well.

Fig. 30 Depression operated accelerator pump

On all accelerator pumps on SOLEX carburetors, the amount of fuel injected and the duration of the injection can be adjusted.

The quantity of fuel injected by mechanical pumps is controlled by the adjustment of the length of the control rod. The control rod, between the intermediate lever on the throttle spindle and the pump lever, has three holes and a split pin for securing the pump lever. Each of these holes corresponds with a different length of pump stroke and therefore the injection of a different amount of fuel (fig. 31). Instead of the holes and split pin, the pump lever may also be secured with an adjusting nut and a lock nut (fig. 32).

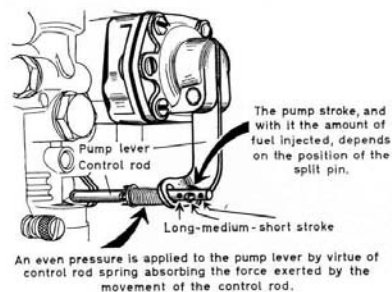

Fig. 31 Adjustment of the quantity of fuel injected with three holes and a split pin

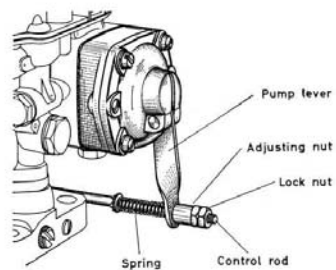

Fig. 32 Adjustment of the quantity of fuel injected with adjusting nut

With depression operated pumps the amount of fuel discharged is determined by the position of the pump valve on the pump membrane spindle.

The duration of the injection depends upon the size of the pump jet  $G_p$ , which regulates the quantity of fuel which can pass through in a given time. It will be clear that the smaller the jet, the longer the fuel will take to flow through it. The size of the pump jet is generally a third of the size of the main jet (Main jet  $G_g = 180$ , Pump jet = 60). It must not be smaller than size 35.

Mechanically operated accelerator pumps are made, according to the carburetor model, in three basic types and a few special ones:

The measurement between the fixing screws of the first type is 27 m/m. The identification number "7" marks this type which is used on downdraught carburetors with a diameter of 32 m/m (except dual port and compound carburetors).

The measurement between the fixing screws of the second type is 35 m/m. This type carries the identification number "8" and is used on downdraught carburetors with a diameter of 35 and 40 m/m also on compound carburetors with diameters of 32 and 44 m/m.

The distance between the fixing screws of the third type is the same, it differs in that a ball valve is fitted in the lower pump body, which in the other types is located in the carburetor body, and that, after drilling and tapping there is the possibility of using an economy jet that is marked with the number "9" and is used on dual port carburetors with a diameter of 30 or 32 m/m.

The 28 PCI carburetor has a special version of the mechanical pump, reduced in size (fig. 33). It has no variable pump jet but a fixed calibrated orifice for the fuel.

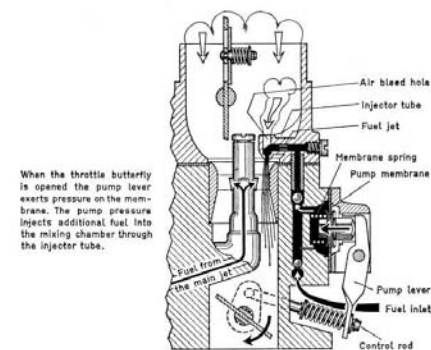

Fig. 33 Accelerator pump of the 28 PCI carburetor

Exceptionally the 40 PII-4 differs from the foregoing basic principles because this dual port carburetor is fitted with an accelerator pump with the identification number "7". This small accelerator pump is sufficient, as this type of carburetor is used especially on racing and sports cars on which each mixing chamber feeds one cylinder only by the shortest way.

In mechanical pumps the full load enrichment and weakening devices are combined. The additional markings of the pump indicate immediately when such a device is incorporated with the pump and if so, of which type it is.

1. If the pump has neither of these devices ("neutral" pump), the number "2" is placed after the identification number (pump types 72, 82 and 92).
2. If the pump has a full load enrichment device ("rich" pump), the number "3" is added to the identifying number (pump types 73, 83, 93).
3. If the pump has a device for full load weakening ("weak" pump), the number "4" is placed after the identification number (pump types 74, 84, 94).

Pumps for downdraught compound carburetors are also marked with the number "1" (pump types 821, 831 and 841).

The enriching or weakening devices may have either ball or disc valves (figs. 34 to 36).

The pump valve is closed when the throttle butterfly is in the part load position. Additional fuel cannot be discharged.

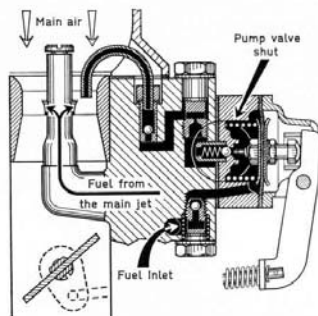
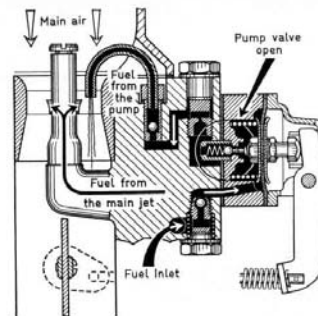

Fig. 34 "Rich" pump with ball valve (pump 73)

a) Part Load

When the throttle butterfly is in the full load position the pump valve is opened. Additional fuel is discharged to enrich the mixture.



b) Full Load

The following general directions can be given for the application of these devices:

1. Pumps with the final number "2" ("neutral" pump) are recommended for all carburetors feeding normal four cylinder engines.
2. Pumps with the final number "3" ("rich" pump) are especially suited for carburetor feeding four cylinder sports cars normal six or eight cylinder engines supercharged engines.
3. Pumps with the final number "4" ("weak" pump) are suitable for use on all carburetors feeding only one, two or three cylinders.

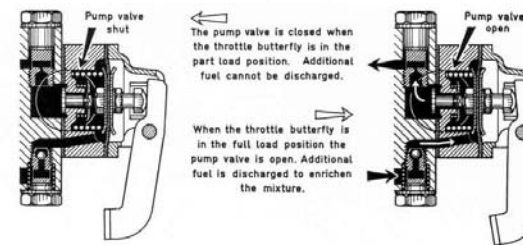

Fig. 35 "Rich" pump with disc valve (pump 83)

a) Part Load

b) Full Load

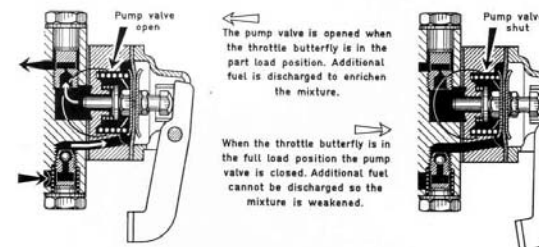

Fig. 36 "Weak" pump with disc valve (pump 84)

a) Part Load

b) Full Load

The fuel from the accelerator pump is normally discharged into the mixing chamber through one injector tube (with dual port carburetors two injector tubes or a dual injector tube are used). In exceptional cases the injector tube takes the form of a nozzle cast into the float chamber cover (i. e. carburetor type 28 PCI).

There are two types of injector tubes:

- a) the "high" injector with its mouth at the level of the correction jet,
- b) the "low" injector with its mouth in the venturi throat.

The mouth of the "low" injector lies in the area of greatest depression, which is not so in the case of the "high" injector.

The following directions can be given for their use:

1. It is recommended that "high" injectors should be used with pumps with the final number "2" ("neutral" pumps).
2. When pumps with the final numbers "3" ("rich" pumps) or "4" ("weak" pumps) are used it is better to use "low" injectors.

## 6. The Enrichment Device

The enrichment device is a new development for automatically enriching the fuel air mixture in the higher engine speed range.

The enrichment device is connected with the main jet circuit (fig. 37). Both are placed in cylindrical wells in the float chamber of the carburetor. The first well is supplied with fuel by the main jet Gg and contains the emulsion tube s and the air correction jet a. The fuel/air mixture is discharged through a ring diffuser. The second well is supplied with fuel by the enrichment device fuel jet and is closed at the top by an air jet. It is connected by a cross channel in a bridge to the inside of the emulsion tube in the main jet circuit.

When the engine is working under part load or at full load at low engine speeds only the main jet circuit operates. As the depression increases further it is transmitted through the cross channel in the bridge to the enrichment device. Additional fuel/air mixture is discharged, the amount increasing progressively as the engine speed rises.

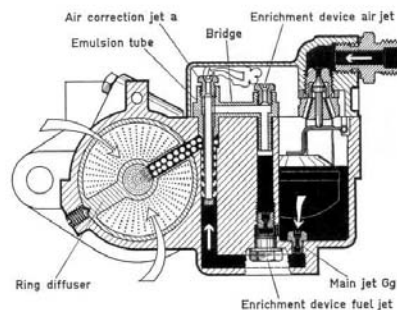
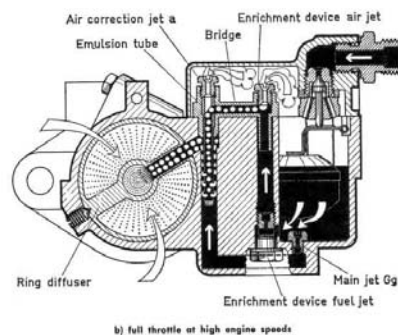

Fig. 37 Operation of the enrichment device of the 44 HR carburetor  
a) full throttle at low engine speeds



b) full throttle at high engine speeds

The size of the air correction jet a (main jet circuit) in relation to the size of the enrichment device air jet determines the additional quantity of fuel.

Instead of specified enrichment jets the flow of fuel and the entry of air into the enrichment device well may be controlled by calibrated drillings (i. e. carburetor type 40 PII-4).

A simplified enrichment device is to be found in the 32 PICB-1 carburetor. An enrichment device tube, located in the float chamber cover is connected with a well in the float chamber into which the fuel is free to flow. The mouth of the rather large calibrated enrichment device tube is approximately on a level with the rim of the float chamber cover, therefore in a zone of comparatively reduced depression. The depression at this point is only great enough to cause additional fuel to be delivered by the enrichment device tube at high engine speeds.

The main jet circuit with fuel enrichment permits fine adjustment and accurate calibration of the fuel supply for the engine taking into account the desired economy and the maximum performance when required.

## V. TUNING THE CARBURETOR

It must be determined if the carburetor feeds:

1. a normal four cylinder engine
2. a four cylinder sports engine, six or eight cylinder engines or a supercharged engine
3. one, two or three cylinders.

### 1. A Carburetor for Normal 4 Cylinder Engines

It is first necessary to determine the size choke tube K which gives the greatest performance (in no circumstances should this be too large, rather a little too small).

During the necessary experiments a slightly larger main jet Gg than the calculated size should be used. In the case of the air correction jet a, calculated in relation to the main jet, the opposite applies so that there is no danger of part of the performance being lost through over-weakening of the mixture.

When the size of choke tube has been decided, the main jet Gg should be reduced until the engine no longer reaches the performance first achieved, keeping the air correction jet the same size.

Then the main jet should be increased and the size which just gives the best performance should be fitted. In this way the first correct point on the consumption curve is determined. On fig. 38 such a curve is shown and this point is marked "A".

It is possible that this setting is not suitable for all working conditions. Especially at  $\frac{1}{4}$  load the curve may lie as shown by the top broken line ("Gg and a as selected"). It can be assumed that at part load the best fuel consumption is not being obtained. To determine whether this is correct it is necessary to check the consumption at the so called "part load point", which is at a speed equivalent to 75% of the maximum speed of the vehicle. This is marked "B" on the diagram.



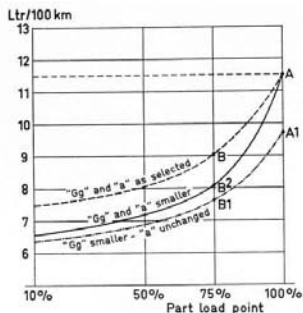

Fig. 38 Consumption curve of a vehicle on a level road

When a test bench is available tests should be taken at a point equivalent to 75% of the peak revolutions and also at an output equal to half the maximum performance. At these speeds the main jet should again be reduced without changing the air correction jet.

If the vehicle still runs well, the main jet should again be reduced until the performance is adversely affected (uneven running, occasional back firing in the carburetor, loss of power). The main jet finally used, that which gives the lowest consumption at 75% of the peak revolutions, should not be changed. The consumption now lies at point "B 1" on the lower broken curve on the chart ("Gg smaller, a unchanged"). This curve lays "parallel" to the upper broken line, to which reference has already been made in the section dealing with the selection of the main jet (fig. 21). Owing to this change point "A" (upper curve) has now moved to point "A 1" (lower curve) indicating that the mixture is too weak at full load operation. The use of a smaller correction jet than that which has been used in the first tests will enrich the mixture under full load. This results in points "A 1" and "B 1" rising to "A" and "B 2" respectively and a final consumption curve as indicated by the continuous line on the diagram.

If at the commencement of the tests the reverse effect is apparent and at part load the mixture is too weak it is necessary to work in the reverse direction and begin by increasing the main jet until the correct part throttle operation is obtained. Then the air correction jet should be increased until the correct mixture strength for maximum performance is reached.

On most engines acceleration can be improved by an accelerator pump. As the SOLEX carburetor, with the correct setting, will provide a trouble free fuel/air mixture for full load and part load operation, suitable as a whole for all four cylinder touring engines, a simple accelerator pump, without additional enrichment or weakening devices can be used. Therefore "neutral" pumps with the indicating number ending in "2" should be used in conjunction with a "high" injector tube. As the mouth of the tube will not be in the area of greatest depression the fuel discharged from the tube will be nil or negligible.

## 2. A Carburetor for 4 Cylinder Sports Engines, for 6 or 8 Cylinder Engines or for Supercharged Engines

In these cases the above procedure cannot be used as the engine requires a very different mixture composition between full load and part load (fig. 39). It is therefore advisable to proceed as follows:

As described at the beginning of the previous section, the size of the choke tube K should first be decided and then a test should be taken at the "part load point" (75% of the maximum speed). This will result in a

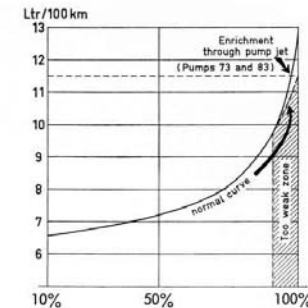

Fig. 39 Consumption curve of a vehicle on a level road with enrichment through the pump jet

main jet Gg and an air correction jet a being determined which will give correct running with the lowest consumption.

It is absolutely essential to use an accelerator pump in these tests with full load enrichment ("rich" pump with the indicating number ending in "3") which allows an additional fuel system to come into operation when the throttle butterfly has nearly fully opened. It is also essential to use a "low" injector tube, the mouth of which is in the area of greatest depression at the discharge orifices of the emulsion tube well.

Using this arrangement tests must be made to attain the highest speed of the vehicle and to determine the smallest pump jet which will give this speed.

Without the fuel supplied through the "low" injector tube and calibrated by the pump jet Gp it is not possible to reach the highest speed. It is essential to select the correct size of pump jet Gp if the maximum speed is to be reached.

Subsequently it has to be ascertained that a good acceleration is assured by the thus determined pump jet Gp within the entire speed range. It will be remembered that the quantity of fuel which is injected can be adjusted (see IV. 5).

## 3. A Carburetor for 1, 2 or 3 Cylinders

This arrangement is usually found on sports or racing car engines or when several carburetors are used on one engine.

It is generally found – as opposed to that in the previous section – that the fuel/air mixture is too weak at part throttle operation (fig. 40).

In this case basically an accelerator pump with full load weakening ("weak" pump with indicating number ending in "4") should be used with a "low" pump injector.

The same tuning procedure as described in section V.1. should be used during which a blank pump jet (without drilling) should be fitted.

However, in this manner the setting determined, has a small main jet Gg and a small air correction jet a. The vehicle should then be driven at 75% of its maximum speed which will give the point "B" on the broken curve in fig. 40.

If the mixture is too weak the blank pump jet should be replaced by a pump jet Gp the size of which is to be suitable to give normal running – always at 75% of maximum speed.

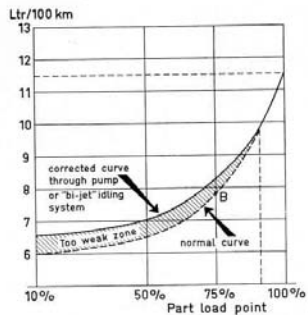

Fig. 40 Influence of the "weak" pump or of a "bi-jet" idling system

However if the engine runs well at the part load point the setting should be left as determined and a "neutral" pump (with indicating number ending in "2"), in conjunction with a "high" injector tube, should be fitted with which the acceleration is satisfactory without enrichment correction.

Sometimes carburetors with "bi-jet" idling systems are also used, with which a correct curve can be obtained without the necessity of using a "weak" pump. This is particularly advantageous in the case of a simple carburetor or if for some reason the accelerator pump does not function satisfactorily. The "bi-jet" idling system gives approximately the same results as a "weak" pump. It has however fewer possibilities of adjustment as it is really dependent on the idling setting.

Only a few types of carburetors and mainly carburetors for racing cars have "bi-jet" idling systems.

## VI. ALTITUDE CORRECTOR

At great heights (over 1200–1500 m/3600–4500 ft), the carburation of vehicle engines presents a problem which can be helped by the SOLEX altitude corrector, as long as there is sufficient space for fitting this device.

As the height increases the mixture gets richer and this is counteracted by the altitude corrector (fig. 41), the flow through the main jet Gg being reduced by a needle which is operated by a barometric capsule.

The altitude corrector is fitted in place of the main jet carrier. The normal main jet Gg is screwed in, in the same way as into the main jet carrier. The fuel flows to the main jet through four large oblique drillings and one small one. The fuel flow through the larger drillings is controlled by the needle connected to the pressure capsule. When the pressure capsule expands under the influence of the decreasing atmospheric pressure, the needle progressively reduces the flow of the fuel to the main jet.

The setting of the altitude corrector is dependent upon the size of the main jet for which it is determined. The size of the main jet should not be changed later, neither should the setting of the altitude corrector be altered. For this reason the adjusting nut, which determines the setting of the altitude capsule in relation to the needle is fitted with a locking washer.

When ordering an altitude corrector it is necessary to quote the engine type, the type of carburetor and the size of the main jet Gg in use.

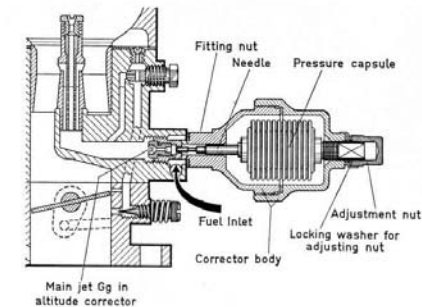

Fig. 41 SOLEX Altitude Corrector

## VII. DEPRESSION OPERATED IGNITION ADVANCE

Most SOLEX carburetors are provided with a threaded drilling, for the connection of a tube for the adjustment of the ignition by depression.

This provision can only be used if the distributor is fitted with a depression operated adjusting device.

The threaded drilling is normally sealed with a screw plug. It is only necessary to remove it to fit the depression tube to the distributor.

## VIII. OPERATING FAULTS

There is no need to fear a complete failure of the SOLEX carburetor. At the worst fitting or adjustment faults may arise.

In the following section various faults and their causes are described. They may be in the carburetor – very often however they are due to other circumstances and their effect is erroneously connected with the carburetor.

### 1. Leakages

#### a) Fuel pipes

Fuel pipes broken or badly soldered – Fuel tap leaking – Fuel filter washers loose or damaged.

#### b) Fuel level too high

Needle valve damaged or too large – dirt preventing the needle valve from closing – float leaking or too heavy – float jamming or sticking – fuel too light – fuel pump pressure too high.

#### c) Washers and gaskets in the carburetor

Insufficiently tightened (i.e. main jet carrier).

### 2. Cold Starting Difficult or Impossible

#### a) Carburetor

No fuel – fuel pump not working – air leaks (throttle spindle, flange washer) – quality of the fuel (Octane rating too low or alcohol content too high) – incorrect starter setting – starter valve incorrectly assembled – starter cable badly fixed – fuel pipe blocked or damaged – needle valve sticking – float chamber empty due to evaporation of fuel.

**b) Ignition**

Ignition as a whole – battery flat – magneto or distributor in bad condition – incorrectly adjusted – dirty or damaged sparking plugs – plug gaps wrong (magneto ignition 0.4 m/m, battery ignition 0.6–0.8 m/m) – contact breaker gaps incorrectly set – condensation on the plugs (inside or outside).

**c) Engine**

Should have the highest possible depression. If this is not the case the cause may be:

aa) Poor sealing: induction pipe badly fitted – slackness in valve guides – valves sticking – valve springs broken – fault in any components connected to the induction manifold.

bb) Cranking speed too low: battery flat – starter faulty – quality and viscosity of lubricating oil (of great importance) – grease in transmission parts too stiff – new or reconditioned engine not run-in.

**3. Hot Starting Difficult or Impossible**

**a) Carburetor**

Fuel pump supply faulty (vapourisation) – percolation of fuel from float chamber – pilot jet too small or blocked – idling set too slow or too weak – induction pipe flooded (with downdraught carburetors start with throttle butterfly fully open).

**b) Ignition**

Fault in the ignition system.

**c) Engine**

Valves burnt – valve springs broken.

**4. Bad Idling**

**a) Carburetor**

Incorrect adjustment of the idling – air leaks (see 2 Cold Starting).

**b) Ignition**

Ignition faulty – plugs oiled up – wrong type of plugs (too cold) – plug gaps different.

**c) Engine**

Uneven compression.

**5. Poor Acceleration**

**a) Carburetor**

Mostly fuel shortage – carburetor setting incorrect (choke tube too large, pump jet too small) – air leaks (see 2. Cold Starting) – insufficient or too much heating of induction pipe – too much cooling – carburetor controls badly assembled (jamming) – over richness in induction pipe due to percolation from the float chamber.

**b) Ignition**

Ignition incorrectly adjusted – automatic advance and retard mechanism erratic – coil too hot – damaged plugs.

**c) Engine**

Engine not running freely (new or reconditioned) – poor compression.

**6. Insufficient Top Speed**

**a) Carburetor**

Carburetor too small – carburetor setting incorrect (choke tube too small, main jet too small, air correction jet too large) – dirt in fuel – throttle butterfly not opening fully – insufficient fuel due to vapourisation in fuel pipe – insufficient pump pressure – needle valve too small – too much heat (in summer).

**b) Ignition**

Ignition insufficiently advanced – automatic advance and retard mechanism sticking – wrong type or damaged plugs.

**c) Engine**

Bearings “dragging” or some other operating fault – poor compression – engine not running freely (new or reconditioned) – cooling insufficient – lubricating oil too thick – silencer choked – brakes binding – wheel alignment not correct.

**7. Insufficient Power when Climbing**

**a) Carburetor**

Carburetor setting incorrect (choke tube too large or too small, main jet too small) – carburetor setting not suitable for fuel in use.

**b) Ignition**

Ignition incorrectly adjusted.

**c) Engine**

Engine not yet warm.

**8. Overheating**

**a) Carburetor**

Carburetor setting incorrect (too weak) – fuel starvation.

**b) Ignition**

Ignition incorrectly adjusted.

**c) Engine**

Engine not running freely (new or reconditioned) – shortage of water – insufficient cooling – choked radiator – unsuitable lubricating oil – insufficient lubrication – silencer choked.

**9. Pinking**

**a) Carburetor**

Carburetor setting too weak – octane value of fuel too low.

**b) Ignition**

Ignition too far advanced – advance and retard mechanism setting unsuitable or out of adjustment.

**c) Engine**

Too much carbon deposited (very important).

**10. Mixture too Rich**

**a) Causes**

Carburetor setting incorrect (main jet too large, air correction jet too small) – main jet opened out or deformed – not genuine SOLEX jets – jets loose – starter in operation or not completely out of action – fuel level too high (see 1. b) – air filter not correctly fitted or clogged – pump pressure too high.

**b) Indications**

Colour of plug points black – black smoke – smell of fuel – engine “hunting” – bad performance.

### 11. Mixture too Weak

#### a) Causes

Carburetor setting incorrect (main jet too small, air correction jet too large) – main jet damaged (reduced in size) – no genuine SOLEX jets – air leaks (see 2. a) – fuel pipes blocked.

#### b) Indications

Colour of plug points white – fused deposits on plug insulators – backfiring in carburetor – pinking – engine overheating – lack of performance – burnt valves.

### 12. Backfiring in the Carburetor

#### a) Carburetor

Carburetor setting too weak (main jet too small, air correction jet too large).

#### b) Ignition

Pre-ignition (plugs too hot, carbon deposits) – fault in ignition system – plug insulator broken.

#### c) Engine

Valves sticking – valve springs broken.

### 13. Detonation in the Exhaust

#### a) Carburetor

Idling too weak.

#### c) Engine

Tapet clearance too small – valves sticking – air leak in exhaust (silencer leaking) – wrong type of plugs.

### 14. Heavy Consumption

Consumption depends upon the following factors: weight of the vehicle, engine speed and average speed, condition and quality of all parts connected with the mechanical transfer of power, carburation, the way in which the vehicle is driven, road conditions (hills, bends), climate conditions and the fuel in use.

Before the fuel consumption of a vehicle can be judged it is necessary to make an accurate fuel consumption test. This must be done very carefully as errors can easily be made when filling up and taking readings. The following directions should be followed:

1. Fit a small auxillary fuel tank which should be connected by a flexible pipe to the fuel pump, or alternatively, direct to the carburetor and placed high enough to supply the carburetor by gravity feed.
2. The auxillary fuel tank should be filled with a glass measure so that the quantity of fuel which is put in can be accurately measured.
3. The vehicle should then be driven over a distance, the length of which is accurately known. The distance should be at least 25 km long and should be similar to the conditions under which the vehicle is normally used.
4. After completing the distance the unused fuel should be measured with the same glass measure.

If the use of an auxillary fuel tank is not possible the vehicle should be placed in a perfectly level position and the fuel tank filled to the brim. The vehicle should then be driven for about 100 km and, after placing the vehicle in a level position again, the fuel tank should be refilled using a measure.

In both cases the fuel consumption, over a 100 km can be easily calculated, on the amount of fuel used.

If the results indicate that the fuel consumption is heavy the following points should be methodically checked, one by one:

#### a) Carburetor

Fuel leakage through washers – float sticking or leaking or too heavy (i. e. after changing to another fuel) – needle valve dirty, worn or too large (when a fuel pump is in use) – air leakage – throttle spindles worn – bad fitting – carburetor setting incorrect (too rich or too weak) – use of enlarged or deformed jets – not genuine SOLEX jets – main jet carrier or main jet cap loose – starter not completely out of action when starter control pushed fully home – induction pipe heating insufficient (especially if fuels of low volatility or containing alcohol are used) – air filter badly fitted, unsuitable or choked.

#### b) Ignition

Ignition incorrectly adjusted (too early or too late) – depression operated ignition advance mechanism of the distributor damaged – plugs damaged, too old or not suitable for the engine (too hot or too cold) – everything affecting the quality of the spark (plug gaps, contact breaker point setting etc.).

#### c) Engine

Engine not running freely (new or reconditioned) – lack of compression – valve timing incorrect – burnt valves or valve springs too weak – exhaust pipe choked – slipping clutch – everything which reduces the performance and can cause overheating of the engine.

#### d) Chassis

Everything which can increase the rolling resistance of the vehicle.

#### e) Radiator

In winter it is sometimes advantageous to limit the cooling (thermostat, radiator blinds).

Finally, it should not be forgotten that there are many other factors which can influence fuel consumption appreciably, bad weather, headwinds, frequent stopping, erratic driving (rapid acceleration, heavy braking) and so on.

## APPENDIX

### AUTOMATIC STARTER (HOT AIR)

#### 1. MODEL BICT

##### A. DESCRIPTION

In the BICT model, a rotating starter disc valve (1) is connected by a spindle (2) to the bimetallic spring (3) which is enclosed in a watertight and thermally sealed body. One end of the spring (3) is fixed to the body in such a way that a rise in temperature allows the spring to expand and turn the disc valve in a rotary movement. To ensure that the spring is heated, the body is connected by an external tube (5) to a refractory U shaped tube (6) dropping right into the hot exhaust gases and joined to atmosphere by a filter (7). The casing is at another point, connected by a channel (4) to the inlet manifold. Thus, the predominant depression in the inlet manifold draws in the air by a drilling (7). This air is heated in the tube (6) and transmitted to the spring (3) before entering the engine. The disc valve has different inlets and a communication (8) with the general air inlet of the carburetor. This communication forms the starter air jet.

The fuel is fed through a channel (9) which draws the fuel from a well (10) fed by the starter fuel jet (Gs). This well (10) is vented at the top into the float chamber which is under a constant level.

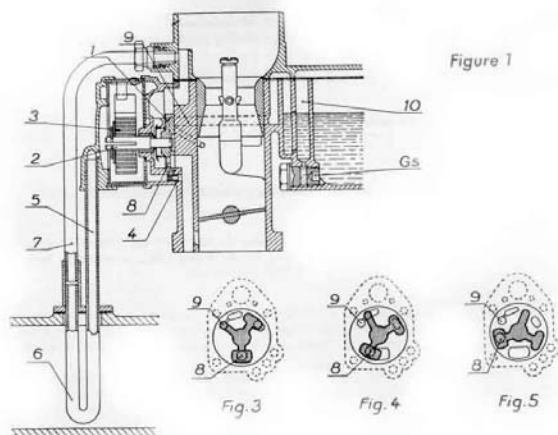

Figure 1

##### B. OPERATION

When the engine is cold, before it is started, the ports are in the positions of figures 1 and 3, that is to say the disc valve ports are in direct communication with the equivalent ports provided on the face on which the disc valve rests.

At the time of starting, when driven by the starter motor, the engine turns, the fuel is fed via the channel (9) and the air by the orifice (8).

When the engine is running and the spring is warmed by the passage of hot air, the disc valve begins to turn, first taking the position of figure 4 where only part on the disc valve (shaded) is opposite the disc valve ports on the face, thus causing a progressive weakening of the mixture, this action continues until the disc valve ports do not communicate with the parts on the face (figure 5). At this point the choke is completely out of action and the engine is idling. At least, when the disc valve is in the position of figure 5, a light spring becomes fixed in a slot of the spindle (2) to keep the disc valve (1) out of action. In order that this spring releases itself from the slot so that the disc valve can take up its working position again, it is necessary to considerably lower the temperature at which the spring is operative. This device aims at avoiding a too rapid or premature return to action of the choke when the engine cools slightly during a brief halt.

#### 2. MODEL ICBT

##### A. DESCRIPTION

In the ICBT carburetor, the function of the Autostarter is similar to that of the BICT but it has an additional device, for certain engines, to obtain an improved restart when the Autostarter is still in action.

In the ICBT, the fuel is delivered by a channel (9) which draws the fuel from a well (10) fed by the starter fuel jet (Gs). This well (10) opens at the top into a circular well (11) the centre of which is connected with the inside of the float chamber by the channel (12). The orifice of this channel (12) can be closed by a membrane valve which is subject to the depression of the manifold through the tube (13), in such a way that, at rest or with a weak depression predominant in the manifold, the passage between the chamber (11) and the channel (12) is closed, and that, at high depressions, this channel is open.

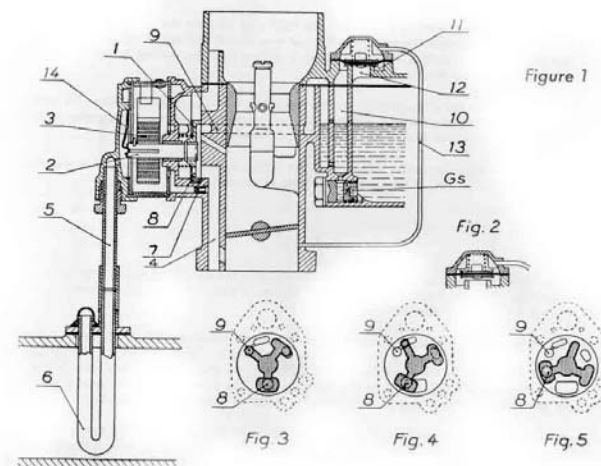

Figure 1

##### B. OPERATION

When the engine is cold, the ports are in the positions of figures 1 and 3, that is to say, the communication between (11) and (12) is closed and the disc valve ports are in direct communication with the equivalent ports provided on the face on which the disc valve rests.

When the engine is running the depression acting in the channel (13) withdraws the membrane and frees the communication between (12), (11) and (10), which has the primary effect of weakening the mixture to stop the engine "hunting" through excess fuel. Then as the spring is warmed by the hot air, the disc valve begins to turn, first taking the position of figure 4, where only one part of the disc valve (shaded) communicates with the ports on the face, thus causing a progressive weakening of the mixture and this continues until the disc valve ports do not communicate with any of the ports on the face (figure 5). At this moment, the starter is completely out of action and the engine is idling.

When running on the starter, the accelerator is pressed, the depression in the manifold becomes very weak, the membrane closes the communication between (11) and (12) again thus providing a momentary richening of the mixture to ensure drive away.

The working of the ICBT model is thus exactly the same as that of the BICT.

However, the device retaining the disc valve (1) in the "out of action" position is different; the two small springs acting on the flats of the spindle are replaced, in this model, by a light spring (14) rivetted to the Autostarter cover, the end of which fits into a slot provided in the spindle (2).

### 3. MODEL 1BT

#### A. DESCRIPTION

The 1BT model is similar in its working principle to the ICBT with however the following differences: The mixture is fed through a channel (23) which draws the fuel from a well (30) fed by the Gs. This well opens at its top into the constant level float chamber through a drilling (16). The mixture is fed into the engine through a tube (17) the air by the Ga (8).

A piston (18) determines the size of the mixture passage according to the working conditions. The spring (19) which helps this piston in its high position is calibrated in such a way that, with weak depression in the inlet manifold the piston (18) remains in its high position and uncovers the channel (20).

On the other hand, with high depression, the piston (18) is drawn away and the passage between the disc valve ports (25) and the underside of the butterfly is closed except through the drilling (21).

#### B. OPERATION

In cold weather and when the engine is cold, the piston occupies the position (figure 1) and the disc valve the figure 2 position, that is to say, the disc valve ports (25) are in direct communication with the equivalent ports on the face on which the disc valve rests.

At the time of starting, when the engine turns, driven by the starter motor, the depression in the inlet manifold is relatively weak. The piston (18) keeps high position (figure 1) and the fuel passes through the channels (23) and (20), when the air is fed through the orifice (8); the mixture is then very rich. On the other hand, when the engine is running, the depression becomes high, the piston (18) is withdrawn (figure 2) and the fuel only comes through the orifice (21) which has the effect of weakening the mixture.

As the spring is warmed by the passage of hot air, the disc valve begins to turn, first taking the position of figure 3 where only one of the ports of the disc valve (shaded) communicates with the orifices on the face, thus causing a weakening of the mixture. After acceleration, the butterfly is open or partly open, the depression in the inlet manifold becomes weak, the piston (18) rises again (figure 4) and the passage of fuel through the large channel (20) is unrestricted. This increase in diameter with a subsequent increase in volume of the mixture to ensure drive away.

As long as the choke is not cut off, the action of the spring continues until the disc valve ports do not communicate any more with the ports on the face (figure 4) and, at this moment the starter is completely out of action.

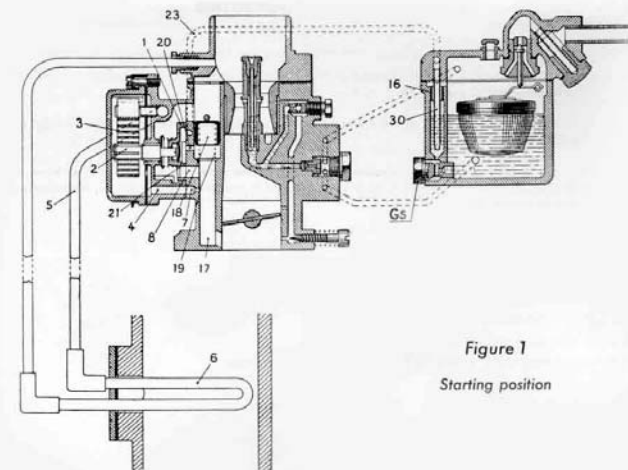

Figure 1  
Starting position

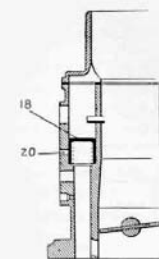

Fig 2  
Starter in action  
(after starting)

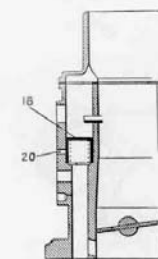

Fig 3  
Starter (progression)  
(Idling)

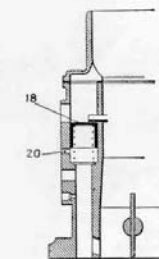

Fig 4  
Starter "out of action"

#### 4. SETTING AND DISMOUNTING

The setting of the Autostarter is fixed at the time of fitting in the workshop and it is carried out with the help of a thermometer and a special setting pointer.

The setting of the Autostarter consists essentially in calibration of the spring after it has been warmed up to the surrounding temperature.

It is therefore, absolutely inadvisable to separate the spring from the starter body. On the other hand, if, after a certain working time, it is suitable to carry out a check or a change of the Autostarter, the following operations may be carried out.

##### a) ICBT Model (fig. I)

- (1) Unscrew the biconical joint.
- (2) Unscrew the two fixing screws on the cover.
- (3) Take off the Autostarter cover.
- (4) Remove the casing and its insulation.
- (5) Take off the body of the Autostarter by removing the 4 fixing screws.

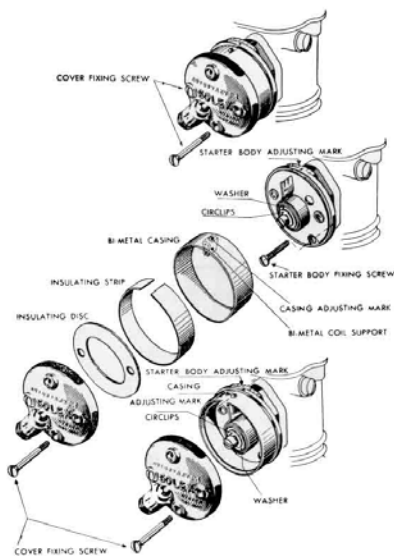

Figure I

##### b) IBT Model (fig. II)

- (1) Unscrew the biconical joint of the warm air intake tube.
- (2) Unscrew the 3 ring fixing screws.
- (3) Take off the adjusting ring.
- (4) Take off the casing.
- (5) Unscrew the 4 body screws of the Autostarter.
- (6) Take off the Autostarter body.

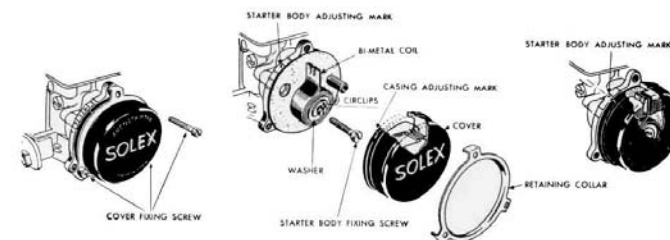

Figure II

##### c) BICT Model (fig. III)

- (1) Unscrew the two cover fixing screws.
- (2) Remove cover, disengaging it from the upper end of the hot air pipe.
- (3) Take off cover insulating washer.
- (4) Remove casing.
- (5) Remove insulation inside casing.
- (6) Unscrew the 4 body fixing screws.
- (7) Remove the Autostarter body.

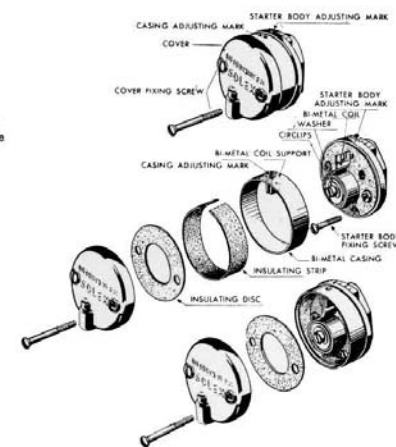

Figure III

**IMPORTANT.** Never remove the pin or the locking device of the bi-metal coil on the starter disc valve spindle.

### 5. RE-FITTING OF AN AUTOSTARTER

When re-fitting an Autostarter on to a carburetor, the following precautions should be taken:

- Firstly, check that the word SOLEX stamped on the straight end of the bi-metal coil is well to the right on the inner face, looking at the starter from the plan view (see fig. 1).
- Secondly, ensure that the free end of the bi-metal coil is securely affixed in the bracket forming part of the casing, or in the slot provided in the starter cover (depending on the type of starter).
- Thirdly, that the mark situated (according to the type of starter) either on the casing or on the Autostarter cover, is correctly located in relation to the "pop" mark made on the starter body during setting in our Works.
- The complete Autostarter should be fitted to the carburetor body with the fixing screws, of which, depending on the model, there are either four or two.
- Next, connect the hot air pipe to the Autostarter with the union and olive, which must seal perfectly. Beforehand, it is suggested that compressed air be blown through the hot air pipe, to ensure that it is quite free of obstruction.

### Some SOLEX Carburetors

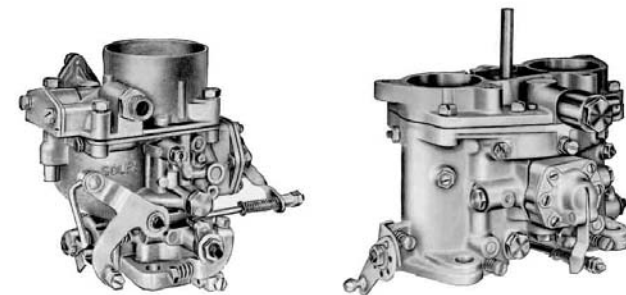

Type 32 PAATI (Dual-port Downdraught Carburetor) Type 40 PII-4 (Dual-port Downdraught Carburetor)

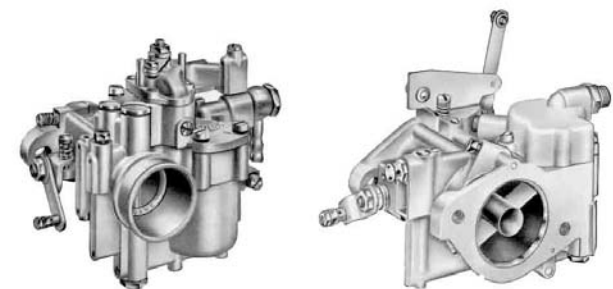

Type 32 HR (Horizontal Carburetor)

Type 44 HR (Horizontal Carburetor)

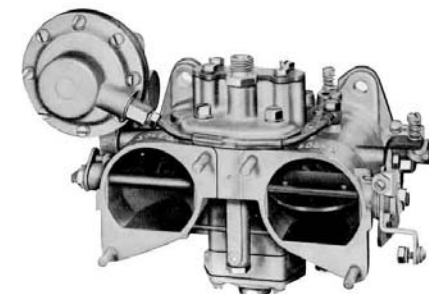

Type 44 PHH (Horizontal Compound Carburetor)